



**Assessment report  
on a quality-assurance system  
Directive 2014/68/EU  
Modules D1 / D / H / H1**



<input type="checkbox"/>	Initial assessment	<input type="checkbox"/>	Unexpected visit	Notified Body's ID	-0090-
<input checked="" type="checkbox"/>	Regular visit	<input type="checkbox"/>	Finding	Report No.	PL04/50160/22

Date of visit: 28.01.2022      Date of documentation review: 28.01.2022

Applicant: KU V-AXX Sp. z o.o., Ściborzyce Małe 94, 48-100 Głubczyce

Representative(s): Dr. Gregor Gaida

1<sup>st</sup> Inspector: Karol Dubas

2<sup>nd</sup> Inspector: \_\_\_\_\_

Quality-assurance system	<input type="checkbox"/>	ISO 9001	<input checked="" type="checkbox"/>	2014/68/EU	Module H1
--------------------------	--------------------------	----------	-------------------------------------	------------	-----------

QAS certified by / certificate no.:	Certification Body MS of TÜV Thüringen e.V.	151001910514
Status Certification Body Mgt.:	----	Date of QAS certification audit: 26.02.2019
Scope ISO 9001/EA-Scope No.:	Design, manufacture and sale of industrial fittings	17, 18

Issuance date QA-manual: 2019-11-28

Scope 2014/68/EU: Industrial fittings made of steel, austenitic cast steel, non-ferrous metals and their alloys

**Brief summary of assessment results:**

- Quality Management System compliant with PED 2014/68/EU Module H1 is described in the Quality Management Book II edition of 28/11/2019. It contains 12 Procedures describing the design, manufacture and sale of industrial fittings in KU V-AXX Sp. z o.o.  
All points of the standard PN-EN ISO 9001: 2015 and PED 2014/68 / EU Module H1 are applicable in the quality management system KU V-AXX Sp. z o.o. Processes implemented by KU V-AXX Sp. z o.o. in the design process, the production process, the assembly and sale of pressure equipment, as well as the presence in the structures of the design cell and the Quality Department (responsible, inter alia, for the control, measurement and testing of products), make the organization recognize all the requirements of PN-EN ISO 9001: 2015 and PED 2014/68 / EU Module H1 as applicable to the scope of its quality management system.

----

Certificate recommended

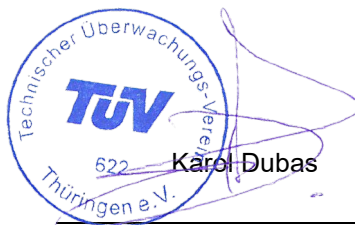

2022-01-28

Date

1<sup>st</sup> Inspector



2<sup>nd</sup> Inspector

Issue of certificate

Team     Contents     Evidence

Certifier's name:

Release

Rejection

2022-01-28

A. Grotkowski

Certification Body for Pressure Equipment of TÜV Thüringen e.V

Date, signature, stamp

## Assessment

<b>1 Organization (D1, D, H, H1)</b>	described	appropriate	applied
Organizational structure / struktura organizacyjna	yes	yes	yes
Responsibilities / odpowiedzialność	yes	yes	yes
Quality objectives / Cele dotyczące jakości	yes	yes	yes
Efficiency monitoring of quality-assurance system / Monitorowanie efektywności systemu zapewnienia jakości	yes	yes	yes

**Remarks:**

1.1. Organizational structure attached, date: 02.01.2021.

1.2 Responsibilities is described in the Book of Quality Management, edition No. 2 of 28/11/2019

1.3 Quality objectives are described in the Quality Management Book, edition No. 2 of 28/11/2019, item 5.2, Annex No. 2 Quality Policy and Form Quality Goals, Quality Purpose Card.

1.4 Efficiency monitoring of quality-assurance details are described in the Procedure PJ-03 - Internal audit, issue 2 of 28/11/2019, the following forms are used: Plan of audits and management reviews, Audit notification, List of audit evidence, Non-compliance report, Audit report, Declaration Auditor, List of persons participating in the audit.

The activity was verified on the basis of the document: Internal Audit Report No. 1/2021 dated 26/02/2021. The result of the verification - no objections.

<b>2 Technical design specification</b>	described	appropriate	applied
Harmonized standards used / Zastosowano zharmonizowane normy	yes	yes	yes
Means for compliance with essential requirements / Środki zapewniające zgodność z zasadniczymi wymaganiami	yes	yes	yes

**Remarks:**

2.1 Harmonized standards used applies to procedure PJ-02 - Supervision of documents and records, edition 1 of 03/09/2018, forms are used: List of supervised documents

The action was verified on the basis of the document: List of supervised documents from 15/01/2021. The result of the verification - no objections.

2.2 Means for compliance with essential requirements are described in detail in the Book of Quality Management, edition No. 2 of 28/11/2019

<b>3 Design (H, H1)</b>	described	appropriate	applied
Methods for review & verification of design results / Metody przeglądu i weryfikacji wyników projektu	yes	yes	yes
Procedures & systematic measures for design process / Procedury i systematyczne środki dla procesu projektowania	yes	yes	yes
Materials: reference to Directive 2014/68/EU, Annex I chapter 4 / Materiały: odniesienie do dyrektywy 2014/68 / UE, załącznik I, rozdział 4	yes	yes	yes
Applicable design codes / Obowiązujące kody projektowe	yes	yes	yes
Design Examination by Notified Body (module H1 only) / Badanie projektu przez jednostkę notyfikowaną (tylko moduł H1)	yes	yes	yes
Design efforts in own responsibility (module H only) / Projektuj wysiłki na własną odpowiedzialność (tylko moduł H)	yes	yes	yes
Capabilities for design quality / Możliwości w zakresie jakości projektu	yes	yes	yes

3.1 KZJ wydanie II punkt 8.3, Procedura Sterowanie projektowaniem PJ-10. Protokół przeglądu , weryfikacji i działań korygujących dla Butterfly valve DN250, BOFI DN 250 serial number 500936. Program do analizowania SOLIDWORKS. Symulacji poddano Butterfly valve DN250, BOFI DN 250 serial number 500936.

QMB edition II point 8.3, procedure Design control PJ-10. Protocol review, verification and corrective actions for Butterfly valve DN250, BOFI DN 250 serial number 500936. SOLIDWORKS analysis program. The simulations were Butterfly valve DN250, BOFI DN 250 serial number 500936.

3.2 KZJ wydanie II punkt 8.3, Procedura Sterowanie projektowaniem PJ-10. Checkliste Montage – Butterfly valve DN250, BOFI DN 250 serial number 500936.

Obliczenia wykonane wg EN 12516 – Armatura przemysłowa – Wytrzymałość obudowy cz. 2 Metoda obliczeniowa dla obudów stalowych armatury.

QMB edition II point 8.3, procedure Design control PJ-10. Checkliste Montage – Butterfly valve DN250, BOFI DN 250 serial number 500936.

Calculations made according to EN 12516 - Industrial fittings - Strength of the casing part. 2 Calculation method for steel armature casings. Each part of the pressure bearing housing is calculated using the finite element method. For this purpose, we use both IDEAS and SolidWorks.

3.3 Procedura PJ-06 Zakupy. Zestawienie materiałowe dla Butterfly valve DN250, BOFI DN 250 serial number 500936.

Procedure PJ-06 Shopping. Bill of materials for Butterfly valve DN250, BOFI DN 250 serial number 500936.

3.4 Obliczenia wykonane wg EN 12516 – Armatura przemysłowa – Wytrzymałość obudowy cz. 2 Metoda obliczeniowa dla obudów stalowych armatury.

Calculations made according to EN 12516 - Industrial fittings - Strength of the casing part. 2 Calculation method for steel armature casings.

3.5 Badanie projektu w TÜV Thüringen 0090 Nr. 0821/2786a/19 z 16.09.2019 wg PED 2014/68/EU Moduł H1 dla zaworu Body 1600PN40.

Project examination at TÜV Thüringen 0090 No. 0821 / 2786a / 19 from 16/09/2019 according to PED 2014/68 / EU Module H1 for Body 1600PN40 valve

3.6 Instrukcja obsługi przepustnic Serii V-AXX wydanie 12/2020. Zawór Butterfly valve DN250, BOFI DN 250 serial number 500936.

Operation manual for butterfly valves Series V-AXX issue 12/2020. Butterfly valve DN250, BOFI DN 250 serial number 500936

3.7 Certyfikat nr SO/2021/00147 – Butterfly valve DN250, BOFI DN 250 serial number 500936.

<b>4 Manufacture (D1, D, H, H1)</b>	described	appropriate	applied
Manufacturing techniques/ Techniki wytwarzania	yes	yes	yes
Quality control techniques/ Techniki kontroli jakości	yes	yes	yes
Quality-assurance techniques/ Techniki zapewnienia jakości	yes	yes	yes
Approved procedures for permanent joining/ Zatwierdzone procedury stałego łączenia	n.a.	n.a.	n.a.
Inspections/examinations/tests before, during, after manufacture/ Przeglądy / badania / testy przed, w trakcie, po zakończeniu produkcji	yes	yes	yes
Frequency of inspections/examinations/tests/ Częstotliwość kontroli / egzaminów / testów	yes	yes	yes
Traceability of materials/ Identyfikowalność materiałów	yes	yes	yes
Capabilities for the quality of pressure equipment/ Możliwości dotyczące jakości urządzeń ciśnieniowych	yes	yes	yes

**Remarks:**

4.1 Manufacturing techniques / Production techniques details are described in the Quality Management Book, edition No. 2 of 28/11/2019 Item 8.5 and the PJ-12 Procedure - Production of industrial fittings edition 1 of 03/09/2018. The main production steps are:

I. Customer order: calculations to meet P and T Customer and PED requirements in SOLIDWORKS simulation; making a BOM (bill of material) with the material specification for each element of the valve; giving the key and number for each variant of the valve.

II. Production preparation: ordering fittings elements at suppliers; detailed description of delivery conditions (type of approval, impact strength, grade, quality of the cast, etc.); delivery - quality control of the delivery, evaluation of delivery compliance with the order.

III. Identification and traceability: each item purchased from the supplier and accepted into the warehouse; each order is marked in a permanent and visible way.

IV. Production: preparation of technical documentation; issuing the "assembly order"; selecting items from the warehouse; assembly.

V. Control and tests: strength test of the body in nominal pressure, tightness testing of the fittings.

VI. Final acceptance and marking of the finished product: checking the conformity of the performance with the technical conditions, design, customer requirements, PED requirements; issuing the Declaration of Conformity and Report, marking with a nameplate according to the following formula:

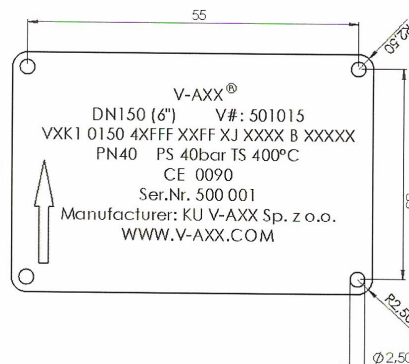

4.2 Quality control techniques / Quality control techniques details are described in the Quality Management Book, edition No. 2 of 28/11/2019 Item 8.5 and the PJ-12 Procedure - Production of industrial valves edition 1 of 03/09/2018 use the following forms: Inspection and testing plan, Inspection report of the shut-off valve, issue from the warehouse, delivery acceptance report.

The action was verified on the basis of the document: Control and testing plan, edition 1, dated 16.12.2020. The result of the verification - no objections.

4.3 Quality-assurance techniques details are described in the Quality Management Book, edition No. 2 of 28/11/2019 Item 10.2 and Procedures PJ-04 - Incompatibilities and corrective actions edition 1 of 03/09/2018, PJ-07 - Handling of incompatible product, PJ -03 - Internal audit, Instruction IJ-01 - Complaints. The following forms are used: Corrective Action Sheet, Audit Plan and Management Review, Audit Notification, List of audit evidence, Noncompliance Report, Audit Report, Audit Declaration, Complaint Register and Complaints.

The action was verified on the basis of the document: List of audit evidence edition 1 of 10/12/2020. The result of the verification - no objections.

4.4 **Approved procedures for permanent joining** for manufactured products are not used.

4.5 Inspections / examinations / tests before, during, manufacture / Reviews / tests / tests before, during, after production details are described in the Quality Management Book, edition No. 2 of 28/11/2019 Item 8.4, item 8.5 and Procedures PJ-12 - Production of industrial valves edition 1 of 03/09/2018 use the following forms: Inspection and testing plan, Inspection report of cut-off valve, Release from storage, Acceptance report of deliveries, PJ-06 - Purchases, forms are used: Delivery acceptance report, Inquiry, Proof of delivery, Order.

The operation was verified on the basis of the document: Checkliste Montage – Butterfly valve DN250, BOFI DN 250 serial number 500936. The result of the verification - without reservations.

4.6 Frequency of inspections / examinations / tests / Frequency of inspections / examinations / tests The details are described in the PJ-12 Procedure - Production of industrial valves edition 1 of 03.09.2018 the following forms are used: Inspection and testing plan, Inspection report, cut-off valve, Edition from the

warehouse, Verified action based on the document: Plan of inspections and tests issue 1 of 16/12/2020. The result of the verification - no objections.

4.7 Traceability of materials The details are described in the PJ-12 Procedure - Production of industrial valves edition 1 of 03.09.2018 the following forms are used: Inspection and testing plan, Inspection report of the shut-off valve, Issue from the warehouse. The action was verified on the basis of the document: Checkliste Montage – Butterfly valve DN250, BOFI DN 250 serial number 500936. The result of the verification - no objections.

4.8. Capabilities for the quality of pressure equipment details are described in the Quality Management Book, edition no. 2 of 28/11/2019 Item 8.5 and Procedure PJ-12 - Production of industrial valves edition 1 of 03.09.2018 the following forms are used: Inspection and testing plan, Inspection report, cut-off valve, warehouse, delivery acceptance report.

The action was verified on the basis of the document: Control and testing plan, edition 1, dated 16/12/2020. Verification result - no objections.

<b>5 Quality Assurance Documents</b>	described	appropriate	applied
Calibration/gauging measurement and test equipment/ Pomiarowe i sprzęt testowy	yes	yes	yes
Qualification/approval of inspection personnel/ Kwalifikacja / zatwierdzenie personelu przeprowadzającego kontrole	yes	yes	yes
Qualification/approval of personnel for permanent joining/ Kwalifikacja / zatwierdzenie personelu do stałego łączenia	n.a.	n.a.	n.a.
Qualification/approval of personnel for nondestructive examination/ Kwalifikacja / zatwierdzenie personelu do badań nieniszczących	n.a.	n.a.	n.a.

**Remarks:**

5.1 Calibration / gauging and test equipment / Calibration / measurement measurements and test equipment details are described in Procedure PJ-09. Equipment and testing and control equipment, edition 1 of 03/09/2018, s Equipment list, Device card, Maintenance and inspection plan, The card of the device for measurements and tests, the list of control and measurement equipment, the schedule of checks, the list of inspection periods, calibration and legalization of control and measurement equipment.

The operation was verified on the basis of the document: Inspection schedule edition 1 of 12.2021 for VENTIL VCB-150 pressure testing machines and OXXON MicroClic MC100 torque wrench. Validation result - no objections.

5.2 Qualification / approval of inspection personnel / Qualification / approval of the personnel conducting the inspection details are described in the Quality Management Book, edition No. 2 of 28/11/2019 Clause 7.1.2 and the PJ-08 Procedure - Training, forms are used: Training plan, Training card employee, Protocol on internal training, Training evaluation sheet.

The action was verified on the basis of the document: Employee training card for Mrs. Agnieszka Mycka and Mr. M. Wieszole and Mr. Adam Kubisztal. The result of the verification - no objections.

5.3 Qualification / approval of personnel for permanent joining - Permanent connections are not used in the company.

5.4 Qualification / approval of personnel for non-destructive testing.

Because permanent connections are not used in the company, non-destructive testing methods are not applicable.

<b>6 Sample for final assessment &amp; document review</b>	available, source	acceptable
Qualification/approval of personnel for permanent joining/ Kwalifikacja / zatwierdzenie personelu do stałego łączenia	n.a.	n.a.
Qualification/approval of procedures for permanent joining/ Kwalifikacja / zatwierdzenie procedur stałego łączenia	n.a.	n.a.
Qualification/approval of NDE personnel/ Kwalifikacja / zatwierdzenie personelu NDE	n.a.	n.a.
Qualification of inspection personnel/ Kwalifikacje personelu przeprowadzającego kontrole	yes, manufacturer	yes
Heat treatment records/ Zapisy do obróbki cieplnej	n.a.	n.a.
Material test reports/ Raporty z testów materiałowych	n.a.	n.a.

Traceability of materials/ Identyfikowalność materiałów	yes, manufacturer	yes
Records nondestructive examinations/ Rejestry badań nieniszczących	n.a.	n.a.
Records destructive examinations/ Rejestry badań niszczących	n.a.	n.a.
Procedures/records on repair during manufacture/ Procedury / zapisy dotyczące naprawy podczas produkcji	n.a.	n.a.
Design output documents/ Dokumenty wyjściowe projektu	yes	yes
Records on experimental design/ Zapisy dotyczące eksperymentalnego projektowania	n.a.	n.a.
Examination & inspection of safety accessories/ Badanie i kontrola akcesoriów bezpieczeństwa	yes	yes
Test pressure [Directive 2014/68/EU Annex I, 3.2.2, 7.4] / Próba ciśnieniowa	yes	yes
Marking [Directive 2014/68/EU Annex I, 3.3] / Znakowanie	yes	yes

**Remarks:**

- 6.4- Graduation diploma at the Faculty of Mechanical Engineering in the field of Mechanics and Machine Construction for Marek Wieszołek of 21/02/2008.  
Graduation diploma at the Faculty of Mechanical Engineering in the field of mechanics and machine construction, in the specialization of computer-aided design and testing of machines for Adam Kubisztal of 05/07/2013.
- 6.7-Inspection Certificate acc. EN 10204-3.1 – No.: WH/OUT/00404 – Butterfly valve DN250, BOFI DN 250 serial number 500936, Customer : KU V-AXX Sp. z o. o., Ściborzyce Małe 94, 48-100 Głubczyce, Date 28.01.2022 , Material 1.4469.
- 6.11- Graduation diploma at the Faculty of Mechanical Engineering in the field of mechanics and machine construction, in the specialization of computer-aided design and testing of machines for Adam Kubisztal of 05/07/2013.
- 6.14- The inspection report DN250 valve, V-Producer KU AXX, serial number 500936 of 2022/01/14.
- 6.15-Name Plate – DN250, Serial No.: 500936, Manufacturer: KU V-AXX sp. z o. o

**7 Statistics**

Assessment period (e.g. within 6 months or annually done) / Okres oceny (np. W ciągu 6 miesięcy lub raz w roku)	01/2022 - 06/2022
Number of the affixed CE 0090 - markings / Numer przymocowanego oznakowania CE 0090 -	500936

Statistics about the affixed CE 0090 – markings have to be recorded. The reference to the validity of respective (Module)-certificate must be ensured, based on time for affixing. Any unclear points & deviations shall be subsequently commented. / Statystyki dotyczące umieszczonego CE 0090 - oznaczenia muszą być rejestrowane. Należy zapewnić odniesienie do ważności odpowiedniego zaświadczenia (modułu), w oparciu o czas na umieszczenie. Wszelkie niejasne punkty i odstępstwa będą następnie komentowane.

**Remarks:**

Ilość wysłanej armatury od 01.01.2021 do 31.12.2021 wyniosła 400 szt.  
The number of fittings sent from 01/01/2021 until 31/12/2021 amounted to 400 pcs

**8 General notes**

**Annexes:**

1. Certyfikat ISO 9001:2015 KU V-AXX Sp. z o.o.
2. Organizational chart
3. Qualifications of designers - Mr. Gregor Gaida, Mr. Adam Kubisztal and Mr. Marek Wieszołek
4. Training PED Mr. Adam Kubisztal, Mr. Marek Wieszołek and Mrs. Agnieszka Mycka
5. Acceptance documentation Butterfly valve DN250, BOFI DN 250 serial number 500936
6. Operation manual for butterfly valves series V-AXX edition 12/2020